

Ultravap®
Levante

porvair
sciences

A U T O M A T I O N - R E A D Y B L O W D O W N E V A P O R A T O R S



Ultravap® Levante

Automation-ready blow down evaporators from Porvair Sciences

- Robot-compatible dry down station for LCMS applications
- Intuitive graphical colour touch screen display
- Up to five stored evaporation programmes
- Up to three programmable steps per method
- On board gas management
- Remote control from PC option
- RS232 connection with full remote control command set
- Reversible screen for integration at side of robot
- Built-in fume management and optional duct connector
- Faster evaporation times
- Choice of 24-, 48-, 96- and 384-well heads
- Small footprint to fit in your hood
- Eco mode extends the life of the heater and fan, if fitted.



The Ultravap® Levante is the latest in Porvair Sciences' popular series of nitrogen blow-down sample concentrators and evaporators. Using technology from our very successful Ultravap® Levante series of robot-ready, integration compatible evaporators we have re-designed the classic single plate evaporator to meet the needs of the modern laboratory.

Now you get full-colour touch screen graphic displays, an integrated auto-ranging power supply and optional fume venting with plug-in fan module. Combined with real-time run displays showing actual gas temperature, gas flow rate and stage height, the Ultravap® Levante puts you more in control of the evaporation process. Offering multi-step ramped programming with full alphanumeric program naming, the Levante is our state-of-the-art standalone evaporator.

The precision engineered mechanism uses a standard ANSI/SLAS plate "nest" to accept most microplate formats and tube racks. It can accommodate tubes up to 80mm in height in a variety of configurations to allow the use of 2 Dram vials, 1.5ml HPLC vials, bar-coded tubes in racks and many other common formats. Evaporator heads are made to match these formats in 24-, 48-, 96- and 384-well configurations. Our unique 96-well spiral needle head, which creates a vortex in certain plates to speed up evaporation, can also be used on the Ultravap® Mistral.

Designed to give you long life in the laboratory, Ultravap® Series evaporators are robustly built with solid

aluminium billet sides, steel cover plates powder-coated for solvent resistance and wide large rubber feet for bench top mounting. The Levante has a built-in fume duct and an optional fan unit is available to speed solvent vapour removal away from the plate, thus increasing the evaporation rate further. New auto-ranging 110/220V power supplies eliminate the need for a transformer and provide sufficient power to drive the heaters and motor without drawing an excessive load, thereby extending the life of your instrument.



▲ All parameters can be programmed through the large colour touch screen display, using the stylus provided.

ACTUAL LENGTH OF THE
ULTRAVAP® LEVANTE

0 1 2 3 4 5 6 7 8 9 10 11

Flexible programming

In comparison with previous models, the Ultravap® Levante has a smaller footprint, allowing better access and saving valuable bench space.

The evaporation table is able to rise under the control of a stepper motor as the drying process proceeds. Precision Swiss-made stepper motors are used in all Ultravaps to precisely control the upward movement of the stage in 0.1cm increments, ensuring that with careful programming, the evaporator head remains just above the surface of the liquid to be removed for optimum efficiency. An on-board digital flow controller allows accurate programming of real gas flow rates for the first time, ensuring reproducible results every time.

Each programme allows the table to rise in up to three distinct ramped phases, so that a fast initial drying period can be followed by a gentler final drying phase. In remote control mode, control commands are sent directly from the robot controller to the Levante. These standard commands are listed in the manual, but most robot manufacturers have drivers available to control the Levante, making integration a seamless process.

	Start mm	End mm	Time min	Temp °C
Demo 1	17.50	40.00	5	60
Run Test	0.00	30.00	8	60
Cool Down	0.00	10.00	1	55
Heat Test	0.00	18.00	8	60
Demo 5	0.00	30.00	8	60

▲ Up to five methods with full alphanumeric names may be stored, edited and recalled. Methods may be sent via RS232 to/from an external computer.

Fast drying					
	Start MM	End MM	Minutes	°C	L/min
Stage 1:	0.00	10.00	6	40	30
Stage 2:	10.00	15.00	6	45	35
Stage 3:	15.00	20.00	10	50	40

▲ Each method consists of three sectors, allowing control of time, gas temperature, gas flow rate and stage height for each sector.

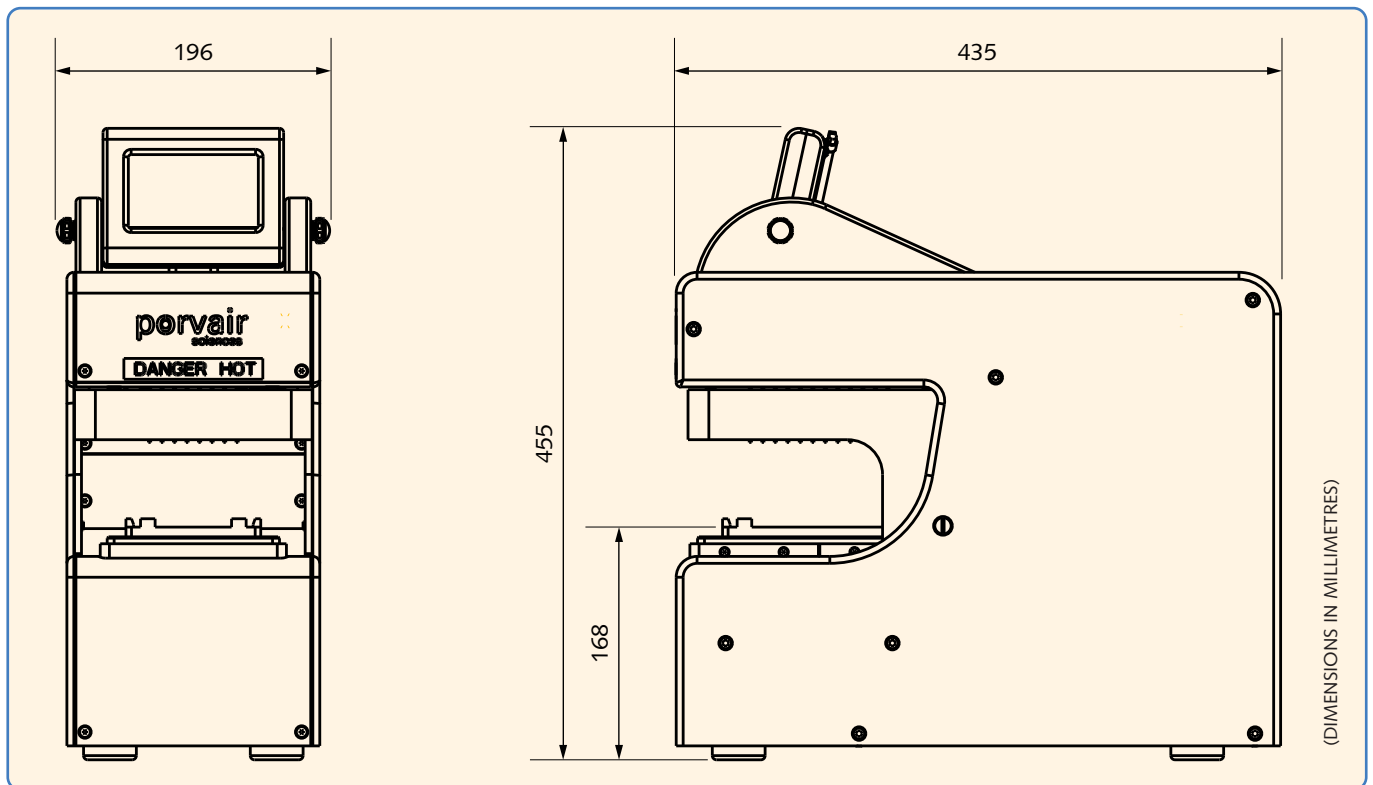

ACTUAL WIDTH OF THE ULTRAVAP® LEVANTE

Flexibility in operation

Any Ultravap® Levante can be operated directly over the built-in RS232 link, so that programming can be carried out remotely and start/stop commands sent from a network. Station I.D. numbers can be set and stored for each unit. Units can easily be taken out of remote control mode for maintenance or where a random-access programme is required.

The Ultravap® Levante comes with an RS232 connection and a remote command set. Whilst not sporting the smart plate "shuttle" of the premium Ultravap® Mistral, it is still possible to connect to and operate from a robot liquid handling station using the Ultravap® Levante. This should appeal to the budget-conscious laboratory who may wish to automate the dry-down bottleneck in the future.

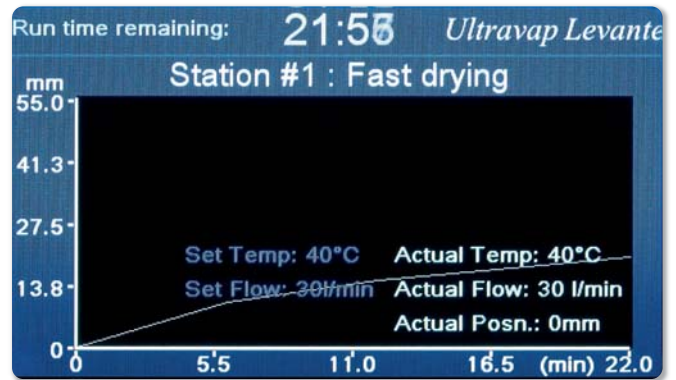

▲ The informative run-time display shows the progress of each evaporation run with real-time information on gas temperature, gas flow rate, stage position and remaining run-time, with an easy to read cursor display.

Method security

Authority to change or edit stored methods is controlled by a password-protected administrative user level in the Levante software, ensuring that unauthorised users cannot tamper with stored protocols. Other users may only recall and run stored methods approved by the administrator.

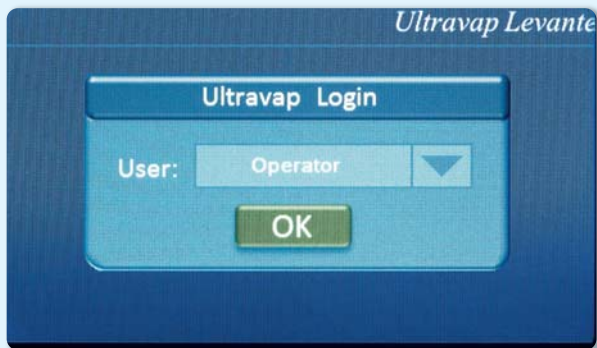

▲ Administrative and user levels can be set and protected by PIN code to prevent unauthorised method editing.

Smart safety

The Ultravap® Levante has been designed to protect you from harm, to protect your robot, if connected, and to look after your samples. The moving plate stage has four sensitive micro-switches to detect obstacles or obstructions. Triggering this safety system automatically stops the Levante and prompts the user to clear the obstruction before re-setting the stage. In addition to the safety role, this system also provides positive plate detection for any robot connected and is able to confirm correct placement of a plate.



▲ Audible and visual warning of any obstruction is clearly shown and must be cleared by the user or the remote operating system for maximum safety.



Solvent compatibility

The Ultravap® Levante is supplied with an evaporator head of your choice, which may be interchanged quickly and easily with a head of a different pattern as your workflow demands. With a choice of 96 straight or 96 spiral needles, plus 24, 48 and 384 straight needles, the sphere of application for Ultravap® Levante is huge. Most common chromatography solvents can be evaporated with ease, including dichloromethane, methanol, acetonitrile and hexane. The nitrogen blow-down method is not, however, suitable for high-boiling point solvents such as DMF, DMSO and water. It is not recommended for use with acids or acid chlorides, as special corrosion-resistant systems are needed for this work. The choice of straight or spiral needles allows the user to choose between faster dry down (spiral) and better final drying in V-well plates (straight). The spirals cause a vortex to form in the solvent, increasing the surface area and thus speeding up the rate of evaporation. Spiral needles are only suitable for use with square-well plates and larger vials.

Evaporator system requirements

The new Ultravap® Levante is designed to run from 110V or 220V at 50/60Hz using an auto-ranging power supply. A built-in digital gas flow meter controls the flow rate and switches off the heaters if the gas supply drops below 30L per minute for maximum safety. Between 30 and 5L per minute, the Levante may be operated without heating using gas at input temperature only. Similarly, if the pressure exceeds 7 bar, safety valves will shut down the system to prevent damage. Optimal gas supply is 70L per minute at 6 bar.

Ordering information

Cat. No.	Description	Qty/Pack
500224	Ultravap® Levante fully robot compatible Blowdown Evaporator with 96 spiral needles, 110/230V	1
500225	Ultravap® Levante fully robot compatible Blowdown Evaporator with 96 straight needles, 110/230V	1
500226	Ultravap® Levante fully robot compatible Blowdown Evaporator without needle head, 110/230V	1
229072	Replacement 96 Needle Head with spiral needles for all Porvair evaporators	1
229036	Replacement 96 Needle Head with straight needles for all Porvair evaporators	1
229073	Replacement 384 Needle Head with straight for Ultravap RC. Mistral & Levante only	1
229409	Replacement 24 Needle Head with straight for all Porvair evaporators	1
229410	Dedicated 48 Needle Head straight for use with HPLC vial adaptor for all Porvair evaporators	1



Simplify the connection of your evaporator to your laboratory robots with Ultravap Mistral. Request a brochure or visit our website - www.microplates.com

porvair
sciences

Sales and Customer Services

Porvair Sciences Ltd Clywedog Road South Wrexham Industrial Estate Wrexham North Wales UK LL13 9XS
Tel: +44 (0) 1978 666222 Fax: +44 (0) 1978 660007 email: int.sales@porvair-sciences.com www.microplates.com

Accounts

Porvair plc 7 Regis Place Bergen Way Kings Lynn Norfolk UK PE30 2JW
Tel: 44 (0)1553 765500 Fax: +44 (0)1553 765599